

Product datasheet

Specifications



Compact base controller, Twido, 100 to 240VAC supply, extendable, 9 inputs with 24VDC, 7 output relays

TWDLCAA16DRF

⚠ Discontinued on: Sep 4, 2023

⚠ End-of-service on: Sep 3, 2025

⚠ Discontinued

Main

Range of product	Twido
Product or component type	Compact base controller
Discrete I/O number	16
Discrete input number	9
Discrete input voltage	24 V
Discrete input voltage type	DC
Discrete output number	7 for relay
[Us] rated supply voltage	100...240 V AC
Use of slot	Memory cartridge or realtime clock cartridge
Data backed up	Internal RAM lithium, 30 days autonomy, charging time: 10 h, battery life: 10 year(s)
Integrated connection type	Power supply Non isolated serial link mini DIN, Modbus/character mode master/slave RTU/ASCII (RS485) half duplex, 38.4 kbit/s Serial link interface adaptor (RS232C/RS485)
Range compatibility	Twido

Complementary

Discrete input logic	Sink or source
Input voltage limits	20.4...28.8 V
Discrete input current	11 mA for I0.0 to I0.1 7 mA for I0.2 to I0.8
Input impedance	2100 Ohm for I0.0 to I0.1 3400 Ohm for I0.2 to I0.8
Filter time	150 µs + programmed filter time for I0.6 to I0.8 at state 0 35 µs + programmed filter time for I0.0 to I0.5 at state 1 40 µs + programmed filter time for I0.6 to I0.8 at state 1 45 µs + programmed filter time for I0.0 to I0.5 at state 0
Insulation between channel and internal logic	1500 Vrms for 1 minute
Insulation resistance between channel	None
Minimum load	0.1 mA
Contact resistance	30000 µOhm
Load current	2 A at 240 V AC inductive load, operating rate <30 cyc/mn for relay output 2 A at 240 V AC resistive load, operating rate <30 cyc/mn for relay output 2 A at 30 V DC inductive load, operating rate <30 cyc/mn for relay output 2 A at 30 V DC resistive load, operating rate <30 cyc/mn for relay output

Price is "List Price" and may be subject to a trade discount – check with your local distributor or retailer for actual price.

Mechanical durability	20000000 cycles for relay output
Electrical durability	100000 cycles for relay output
Current consumption	30 mA at 5 V DC at state 1 40 mA at 24 V DC at state 1 5 mA at 5 V DC at state 0
I/O connection	Non-removable screw terminal block
Network frequency	50/60 Hz
Supply voltage limits	85...264 V
Network frequency limits	47...63 Hz
Power supply output current	0.25 A for 24 V DC sensors
Input current	300 mA
Inrush current	35 A
Protection type	Power protection by internal fuse
Power consumption in VA	22 VA at 100 V 31 VA at 264 V
Insulation resistance	> 10 MOhm at 500 V, between I/O and earth terminals > 10 MOhm at 500 V, between supply and earth terminals
Program memory	2000 instructions
Exact time for 1 Kinstruction	1 ms
System overhead	0.5 ms
Memory description	Internal RAM, 128 counters, no floating, no trigonometrical Internal RAM, 128 internal bits, no floating, no trigonometrical Internal RAM, 3000 internal words, no floating, no trigonometrical Internal RAM, 64 timers, no floating, no trigonometrical Internal RAM, double words, no floating, no trigonometrical
Free slots	1
Realtime clock	Without clock
Counting input number	1 counting input(s) at 20000 Hz 32 bits 3 counting input(s) at 5000 Hz 16 bits
Analogue adjustment points	1 point adjustable from 0...1023
Status LED	1 LED (green) PWR 1 LED (green) RUN 1 LED per channel (green) I/O status 1 LED (red) module error (ERR) 1 LED user pilot light (STAT)
Depth	70 mm
Height	80 mm
Width	90 mm
Terminals description PLC n°1	(1)IN_DIS#1 ALT (3)IN_DIS#3 (-)PW_OUT_NEG (5)IN_DIS#5 (+)PW_OUT_POS TB_TOP (0)IN_DIS#0 (4)IN_DIS#4 COM_NEG#0-8 (2)IN_DIS#2 (8)IN_DIS#8 (6)IN_DIS#6 (7)IN_DIS#7

Terminals description PLC n°2	(7)IN_DIS#7 TB_TOP (-)PW_OUT_NEG (5)IN_DIS#5 (3)IN_DIS#3 (1)IN_DIS#1 (+)PW_OUT_POS (6)IN_DIS#6 (2)IN_DIS#2 (0)IN_DIS#0 ALT_1 (8)IN_DIS#8 (4)IN_DIS#4 COM_POS#0-8
--------------------------------------	---

Terminals description PLC n°3	(COM1)COM#4-5 (6)OUT_DIS#6 (-)PW_NEG (0)OUT_DIS#0 (+)PW_POS (1)OUT_DIS#1 (COM0)COM#0-3 (COM2)COM#6 (5)OUT_DIS#5 (2)OUT_DIS#2 (3)OUT_DIS#3 TB_BOTTOM (4)OUT_DIS#4 (GND)GROUND
--------------------------------------	---

Net weight	0.25 kg
-------------------	---------

Environment

Immunity to microbreaks	10 ms
Dielectric strength	1500 V for 1 minute, between I/O and earth terminals 1500 V for 1 minute, between supply and earth terminals
Product certifications	UL CSA
Marking	CE
Ambient air temperature for operation	0...55 °C
Ambient air temperature for storage	-25...70 °C
Relative humidity	30...95 % without condensation
IP degree of protection	IP20
Operating altitude	0...2000 m
Storage altitude	0...3000 m
Vibration resistance	0.075 mm at 10...57 Hz on 35 mm symmetrical DIN rail 1 gn at 57...150 Hz on 35 mm symmetrical DIN rail 1.6 mm at 2...25 Hz on plate or panel with fixing kit 4 gn at 25...100 Hz on plate or panel with fixing kit
Shock resistance	15 gn for 11 ms

Packing Units

Unit Type of Package 1	PCE
Number of Units in Package 1	1
Package 1 Height	10.5 cm
Package 1 Width	11.0 cm
Package 1 Length	12.5 cm
Package 1 Weight	375.0 g

Unit Type of Package 2	S03
Number of Units in Package 2	12
Package 2 Height	30.0 cm
Package 2 Width	30.0 cm
Package 2 Length	40.0 cm
Package 2 Weight	5.03 kg
Unit Type of Package 3	S01
Number of Units in Package 3	3
Package 3 Height	15.0 cm
Package 3 Width	15.0 cm
Package 3 Length	40.0 cm
Package 3 Weight	1.254 kg

Contractual warranty

Warranty	18 months
-----------------	-----------

Dimensions Drawings

Dimensions

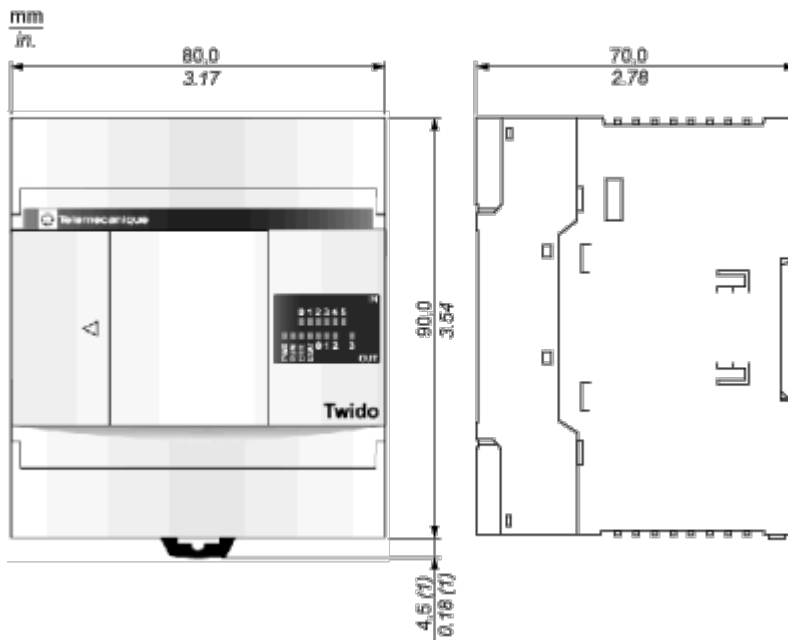

(1) 8.5 mm (0.33 in) when the clamp is pulled out.

Mounting and Clearance

Minimum Clearances for a Compact Base and Expansion I/O Modules

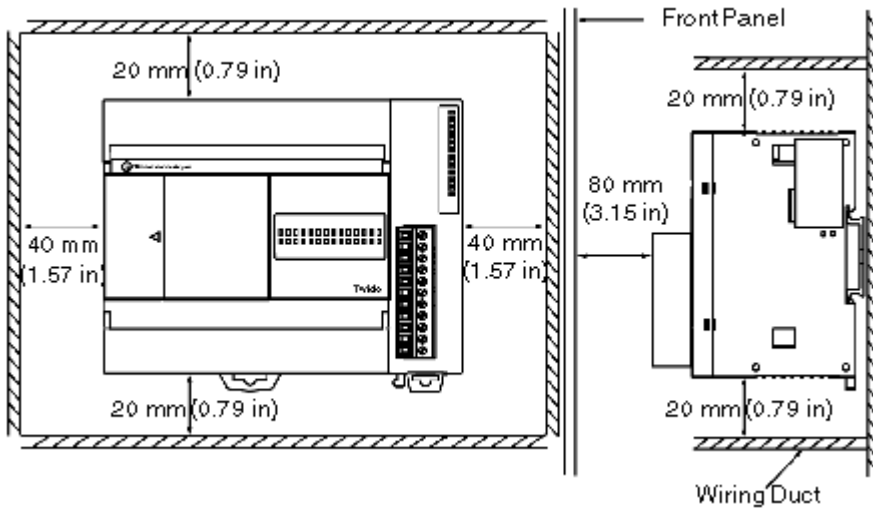

Mounting Hole Layout

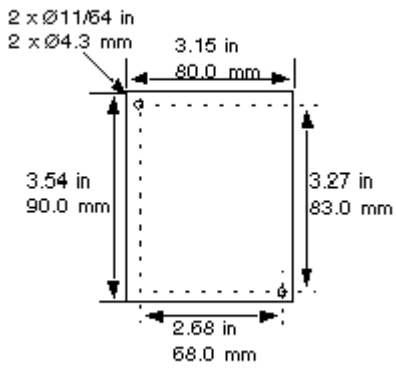

Connections and Schema

AC Power Supply Wiring Diagram

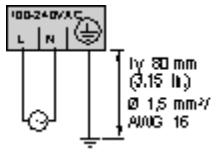

DC Source Inputs Wiring Diagrams

External Power

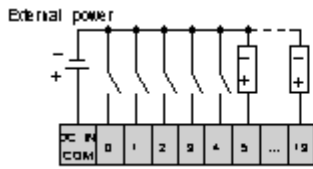

Internal Power

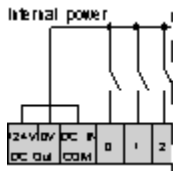

Max current: 250mA.

DC Sink Inputs Wiring Diagrams

External Power

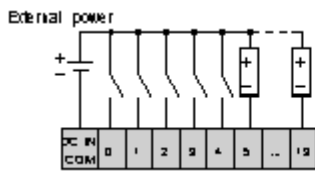

Internal Power

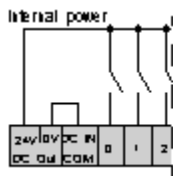

Max current: 250mA.

Relay and Transistor Outputs Wiring Diagram

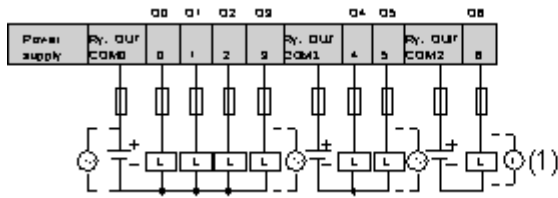

Performance Curves

Performance Curves

I/O Usage Limits

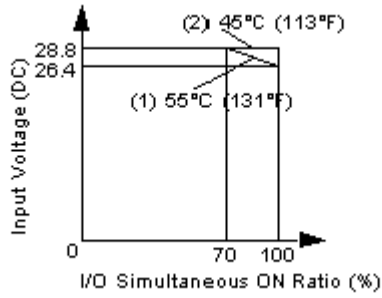

- (1) Limit for TWDLCA•AA16DRF, TWDLCA•A24DRF, TWDLCA•40DRF and TWDLCA•40DRF
- (2) All compact bases